

avenue® B techzone® led

FAVBTZL



FOCAL POINT®

⚠️ AVOID ALL CONTACT WITH LED SURFACE, LEDs ARE EASILY DAMAGED!

FOCAL POINT

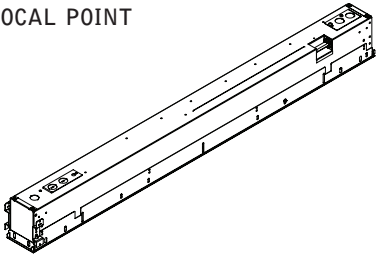

4FT LUMINAIRE WEIGHT: 7LBS

5FT LUMINAIRE WEIGHT: 8LBS

KEY



POWER OFF



POWER ON



ATTENTION

TEE SPACING

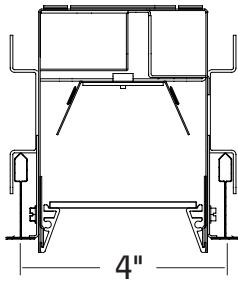

1

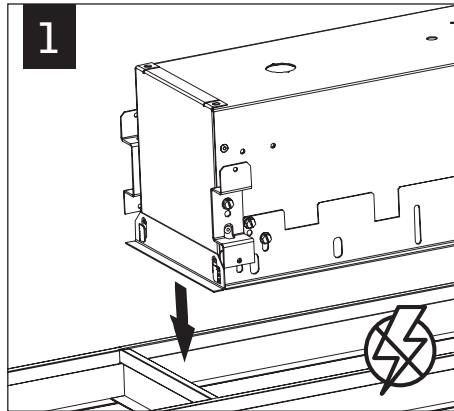

2

IF LUMINAIRE DOES NOT SIT FLUSH, LOOSEN SCREWS TO ADJUST

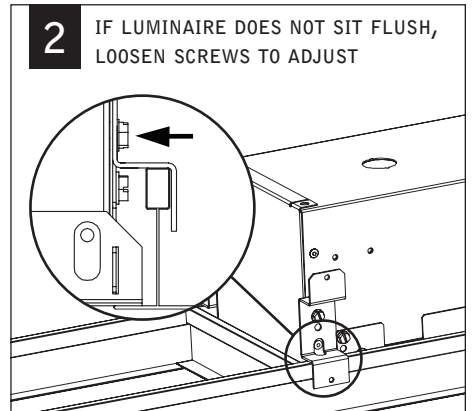

3

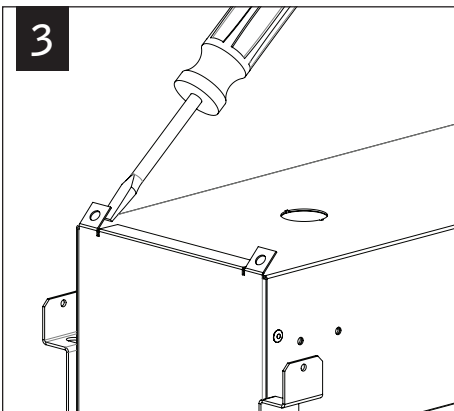

4



SECURE TO STRUCTURE ABOVE

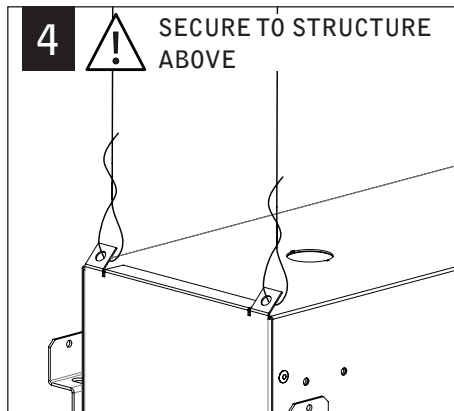

OPTIONAL

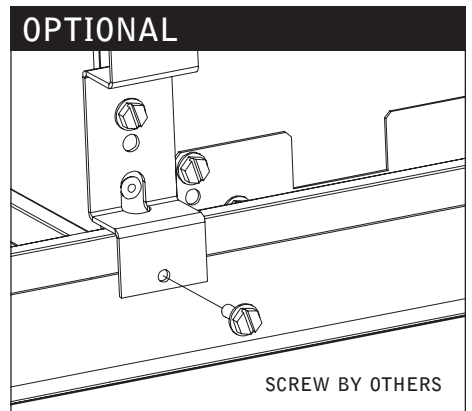

5

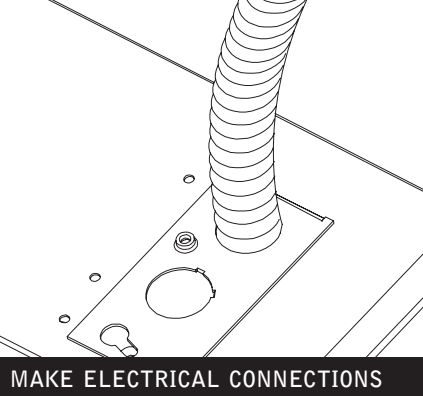
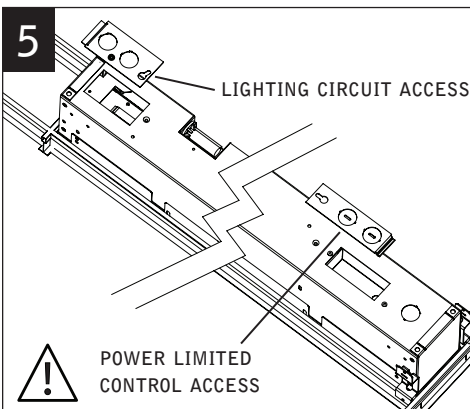

6

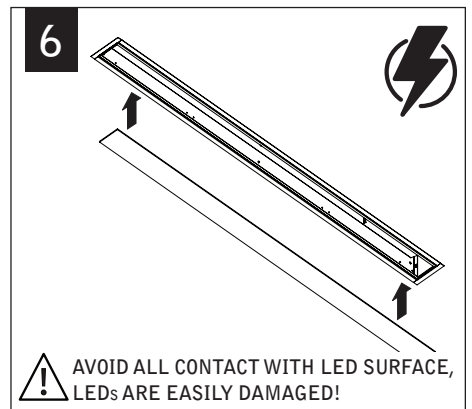

Luminaires must be installed by a qualified electrician (check with local and national codes for proper installation).
To prevent electrical shock, disconnect electrical supply before installation or servicing.

DRIVER SERVICE

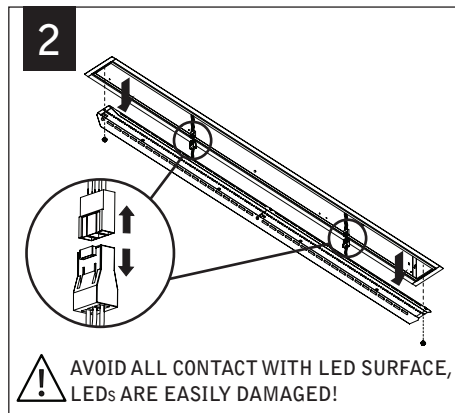
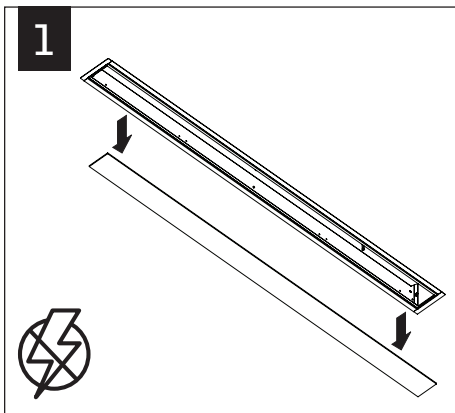

EMERGENCY



SEE BATTERY MANUFACTURER
INSTRUCTIONS

EMERGENCY MAXIMUM MOUNTING HEIGHT:
20.00'