

# seem 4™ led trim flange

FSM4L-TF



**NEW CONSTRUCTION ONLY**  
 ⚠ CONFIGURATIONS ARE RUN SPECIFIC, PLEASE CONSULT FACTORY DRAWINGS BEFORE BEGINNING INSTALLATION. ⚠

**FOCAL POINT**

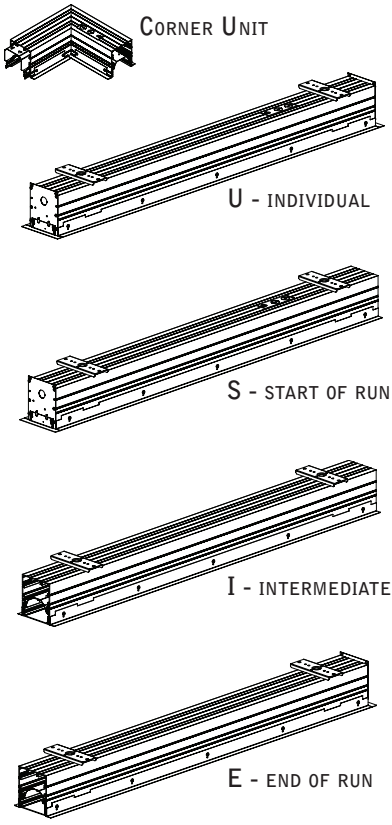

**PARTS LISTS**

INCLUDED HARDWARE
 REFLECTOR SCREW (70008) (6-32 X 5/16 PAN-HEAD MACHINE SCREW)

PARTS SHIPPED INSTALLED	
 JOINER BRACKET (11849)	 MOUNTING BRACKET ASSEMBLY (71904) (17999)
 JOINER BRACKET (11920)	 ALIGNMENT PIN (REGRESS LENS) (22372)
 JOINER BRACKET (REGRESS LENS XFN & XFW) (A32034-01)	 ALIGNMENT BRACKET (REGRESS LENS) (A22092-01)

**KEY**

- POWER OFF
- POWER ON
- ATTENTION

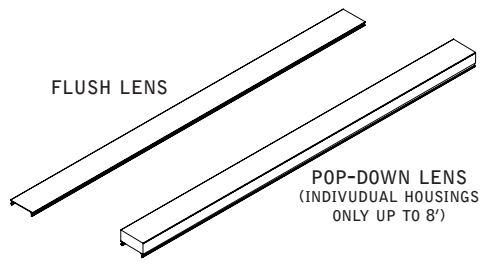

**MOUNTING LOCATIONS**

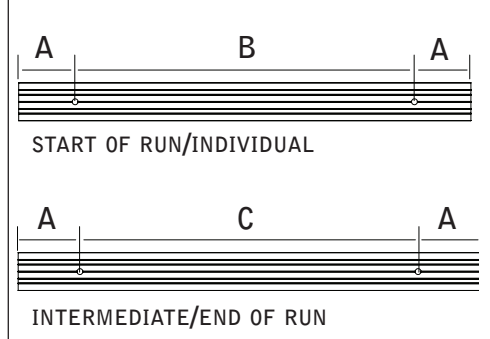

housing length	A	B	C
2'	1"	21"	22"
3'	1"	33"	34"
4'	6"	35"	36"
5'	6"	47"	48"
6'	6"	59"	60"
7'	6"	71"	72"
8'	6"	83"	84"

⚠ MOUNTING LOCATION CHART IS AN APPROXIMATE GUIDE ONLY.

**⚠ MOUNTING BRACKET MUST BE INSTALLED PRIOR TO DRYWALL ⚠**

**⚠**

MOUNTING BRACKET MUST BE SECURED TO STRUCTURE ABOVE.

1/4" - 20 CARRIAGE BOLT MAY BE SUPPLIED BY OTHERS FOR GREATER ADJUSTABILITY.

Luminaires must be installed by a qualified electrician (check with local and national codes for proper installation).  
 To prevent electrical shock, disconnect electrical supply before installation or servicing.

## CEILING CUTOUT

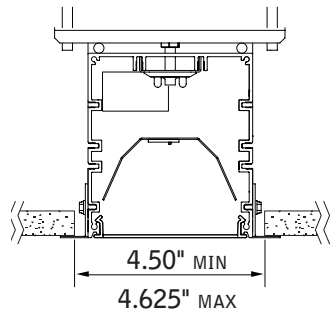

CEILING CUTOUT LENGTH =  
NOMINAL RUN LENGTH MINUS 5/16" (+/- 1/16")

EXAMPLE:  
12' RUN LENGTH = 11' 11-3/4" CUTOUT LENGTH

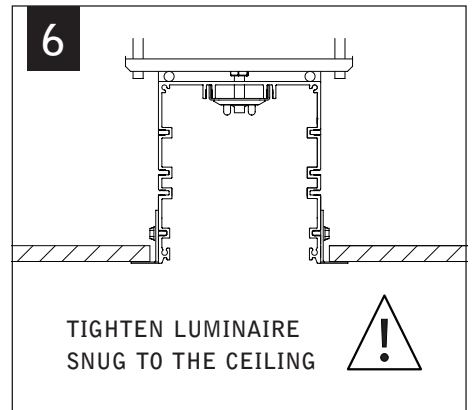
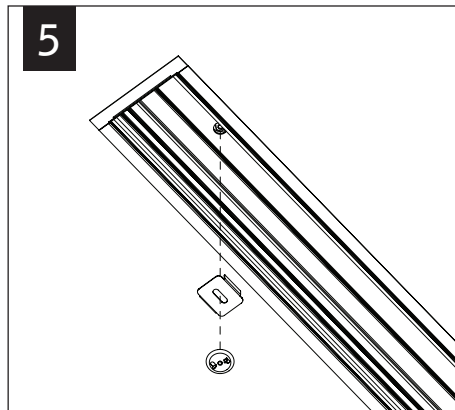
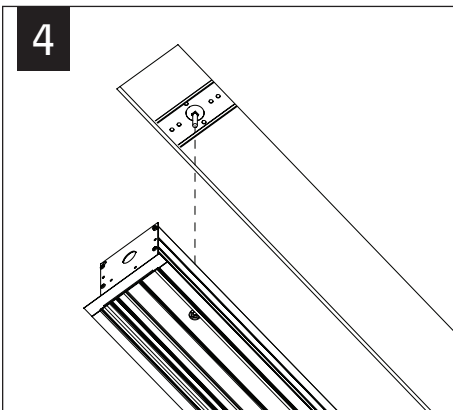
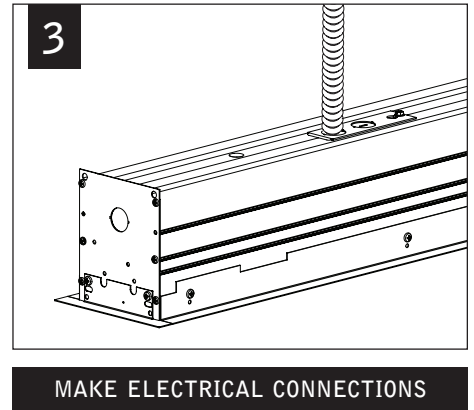
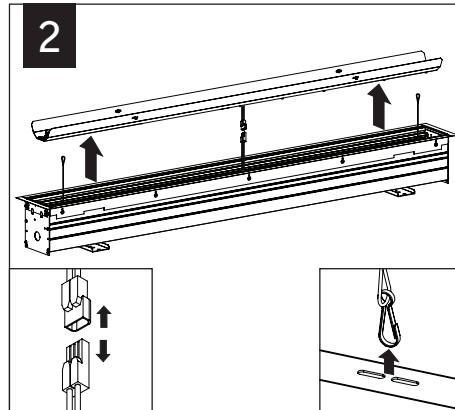
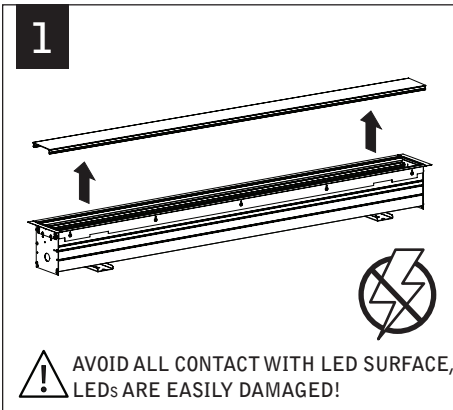
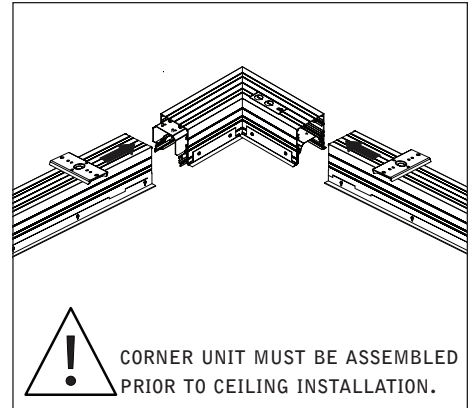

REPEAT STEPS 4-6 UNTIL ALL UNITS ARE IN THE CEILING  
INDIVIDUAL INSTALLATIONS SKIP TO STEP 10

## REGRESS LENS

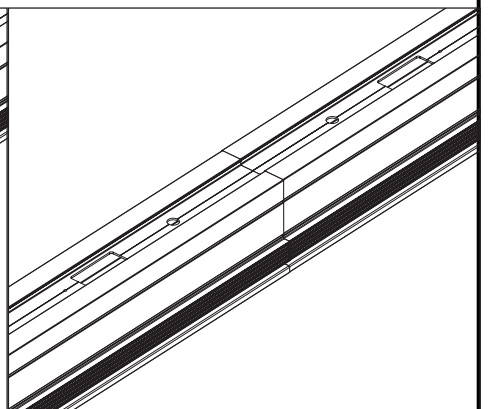
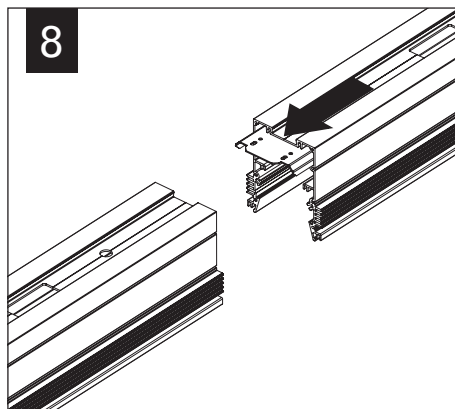
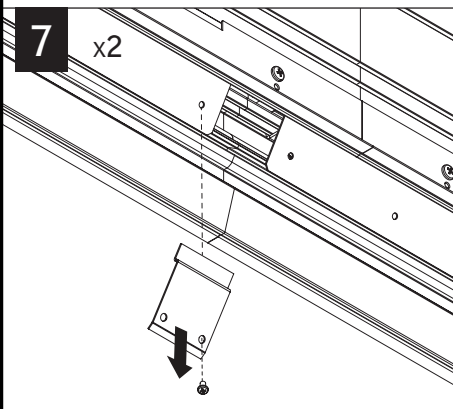

Luminaires must be installed by a qualified electrician (check with local and national codes for proper installation).  
To prevent electrical shock, disconnect electrical supply before installation or servicing.

## REGRESS LENS

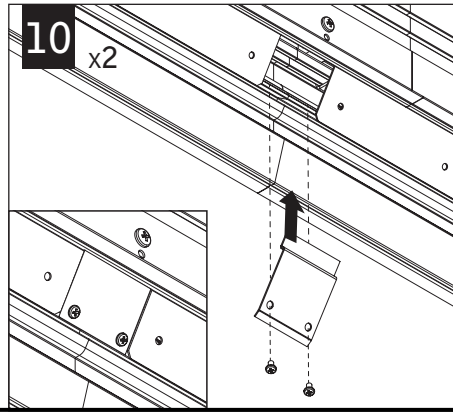
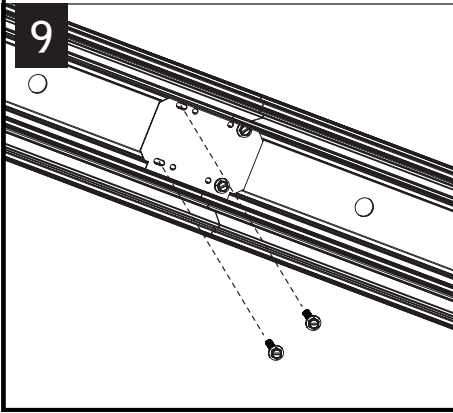

## FLUSH/POP-DOWN LENS

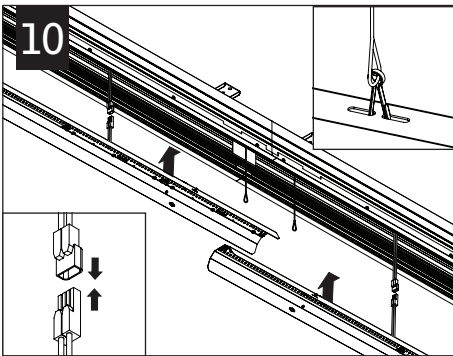
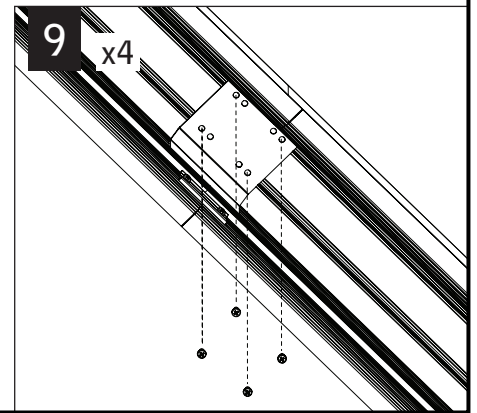
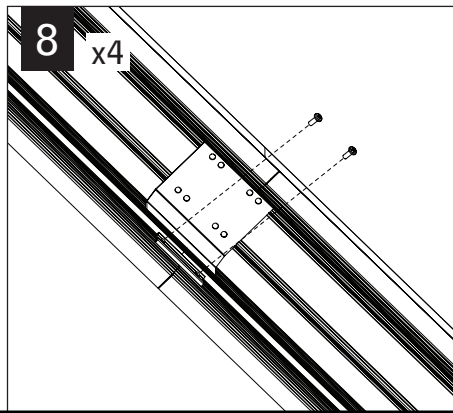
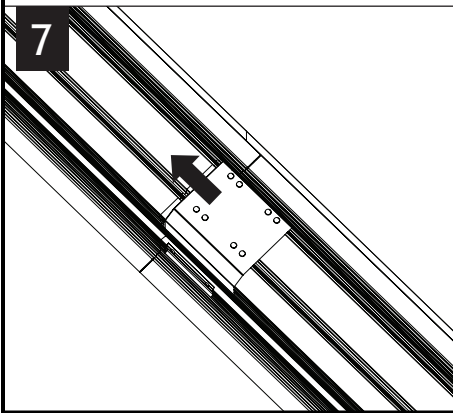

MAKE ELECTRICAL CONNECTIONS

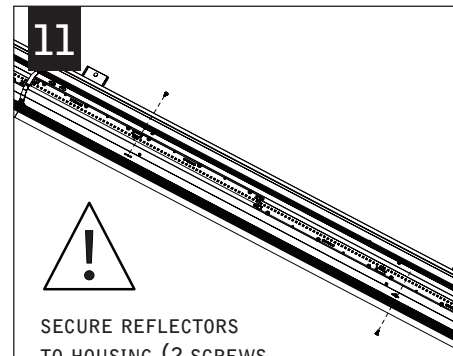

SECURE REFLECTORS TO HOUSING (2 SCREWS PER REFLECTOR)

## FLUSH LENS

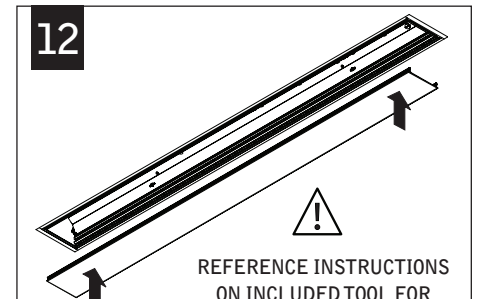

REFERENCE INSTRUCTIONS ON INCLUDED TOOL FOR LENS INSTALLATION.

## POP-DOWN LENS

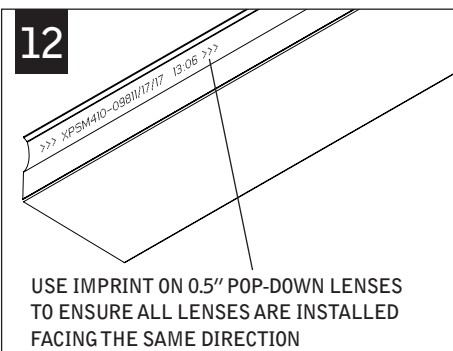

USE IMPRINT ON 0.5" POP-DOWN LENSES TO ENSURE ALL LENSES ARE INSTALLED FACING THE SAME DIRECTION

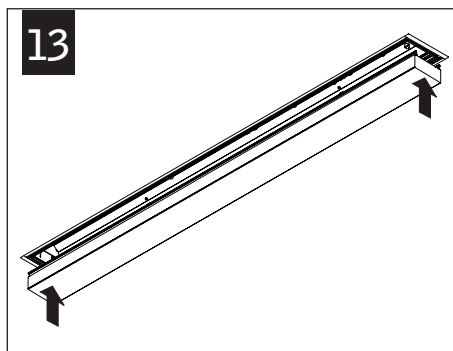

Contractor is responsible for adequately reinforcing walls and/or ceilings to support luminaire weight. Focal Point, LLC accepts no responsibility for inadequately reinforced walls and/or ceilings. The information contained in this drawing is the sole property of Focal Point, LLC. Any reproduction in part or whole without the written permission of Focal Point, LLC is prohibited.

## EMERGENCY



SEE BATTERY MANUFACTURER  
INSTRUCTIONS

EMERGENCY MAXIMUM MOUNTING HEIGHT:  
13.00'

## DRIVER SERVICE

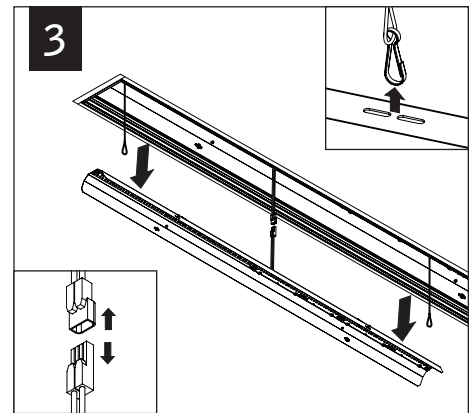
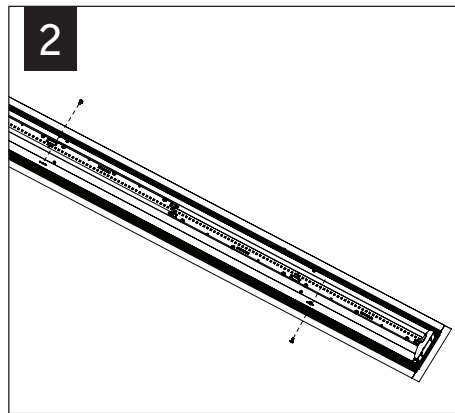
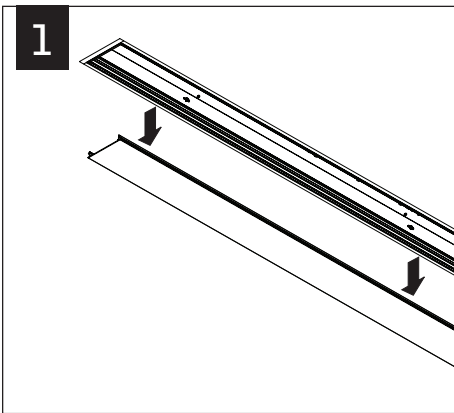

Contractor is responsible for adequately reinforcing walls and/or ceilings to support luminaire weight. Focal Point, LLC accepts no responsibility for inadequately reinforced walls and/or ceilings. The information contained in this drawing is the sole property of Focal Point, LLC. Any reproduction in part or whole without the written permission of Focal Point, LLC is prohibited.