

# seem 6™ led trim flange

FSM6L-TF



**NEW CONSTRUCTION ONLY**  
 ! CONFIGURATIONS ARE RUN SPECIFIC, PLEASE CONSULT FACTORY DRAWINGS BEFORE BEGINNING INSTALLATION. !

**FOCAL POINT**

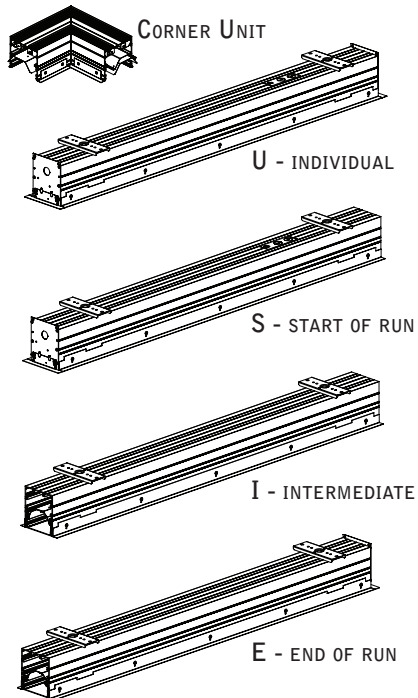

**PARTS LISTS**

| INCLUDED HARDWARE             |  |
|-------------------------------|--|
| REFLECTOR SCREW (72010)       | LENS TOOL (A15966-01)<br>(AFFIXED TO HOUSING, ONE PER RUN) |
| JOINER BULKHEAD SCREW (72010) |  |
| PARTS SHIPPED INSTALLED       |  |
| JOINER BRACKET SCREW (72009)  | JOINER BRACKET (A15328-01)                                 |
| JOINER BULKHEAD (A15570-01)   | MOUNTING BRACKET ASSEMBLY (70001) (17999)                  |
| LENS END PIECE (A12498)       | (71025)  |
|                               | (18495)  |
|                               | (71024)  |

**KEY**

- POWER OFF
- POWER ON
- ATTENTION

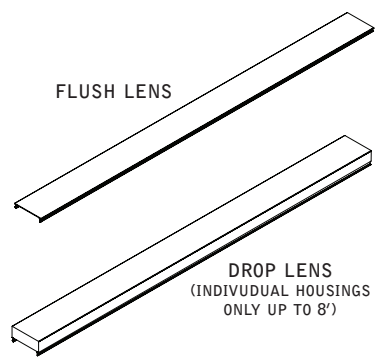

**MOUNTING BRACKET MUST BE INSTALLED PRIOR TO DRYWALL**

**MOUNTING BRACKET MUST BE SECURED TO STRUCTURE ABOVE.**  
 1/4" - 20 CARRIAGE BOLT MAY BE SUPPLIED BY OTHERS FOR GREATER ADJUSTABILITY.

**MOUNTING LOCATIONS**

| housing length | A  | B   | C   |
|----------------|----|-----|-----|
| 2'             | 1" | 21" | 22" |
| 3'             | 1" | 33" | 34" |
| 4'             | 6" | 35" | 36" |
| 5'             | 6" | 47" | 48" |
| 6'             | 6" | 59" | 60" |
| 7'             | 6" | 71" | 72" |
| 8'             | 6" | 83" | 84" |

**MOUNTING LOCATION CHART IS AN APPROXIMATE GUIDE ONLY.**

Luminaires must be installed by a qualified electrician (check with local and national codes for proper installation).  
 To prevent electrical shock, disconnect electrical supply before installation or servicing.

# CEILING CUTOUT

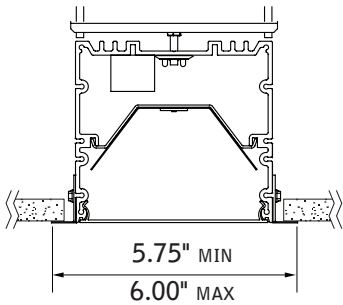

CEILING CUTOUT LENGTH =  
NOMINAL RUN LENGTH MINUS 5/16" (+/- 1/16")

EXAMPLE:  
12' RUN LENGTH = 11' 11-3/4" CUTOUT LENGTH

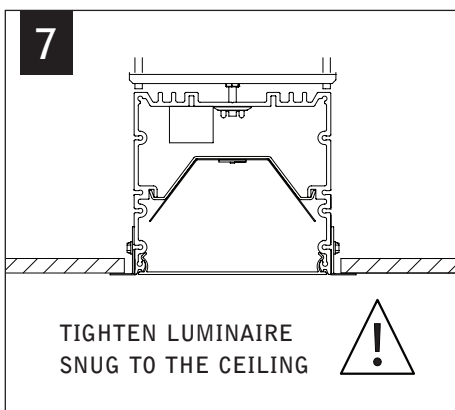
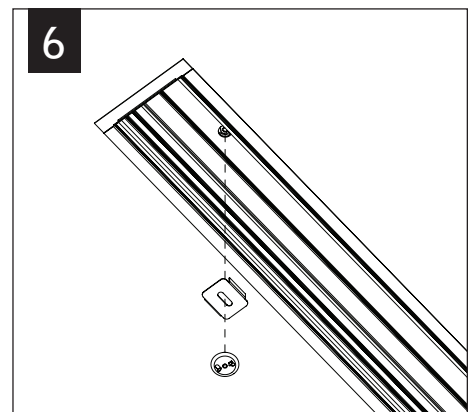
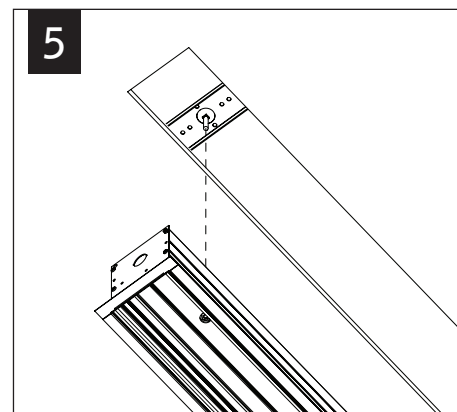
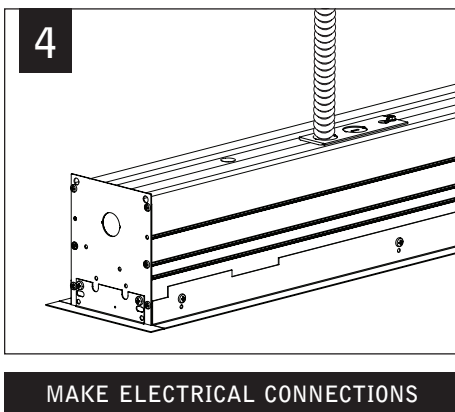
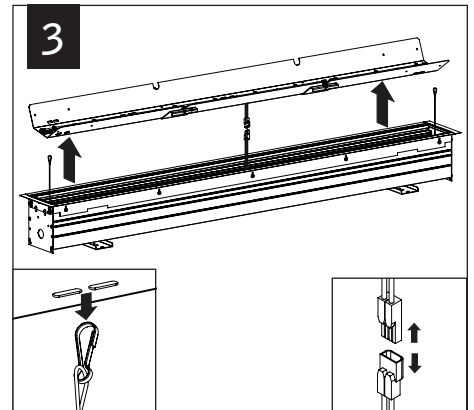
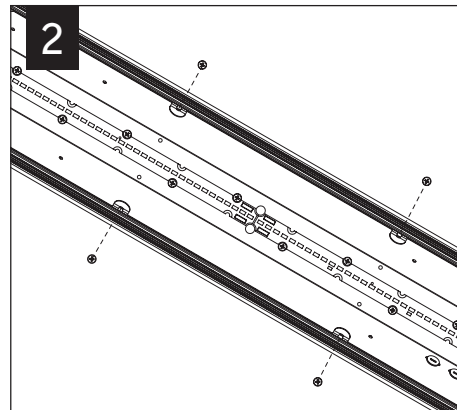
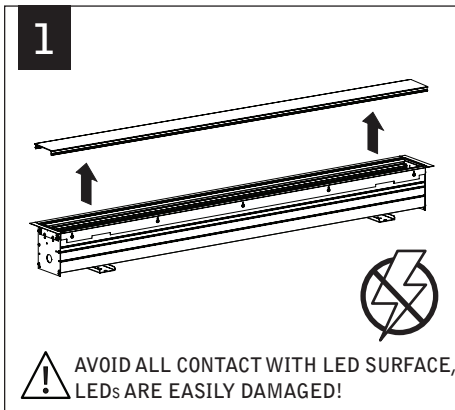
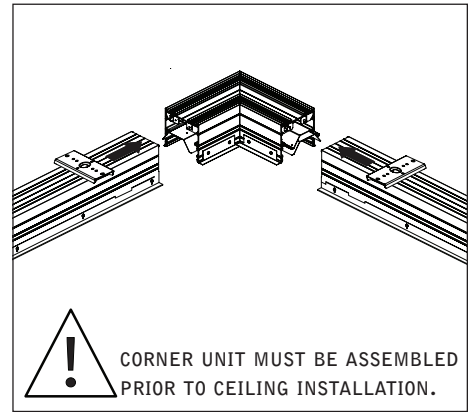

REPEAT STEPS 5-7  
UNTIL ALL UNITS ARE  
IN THE CEILING

INDIVIDUAL INSTALLATIONS  
SKIP TO STEP 11

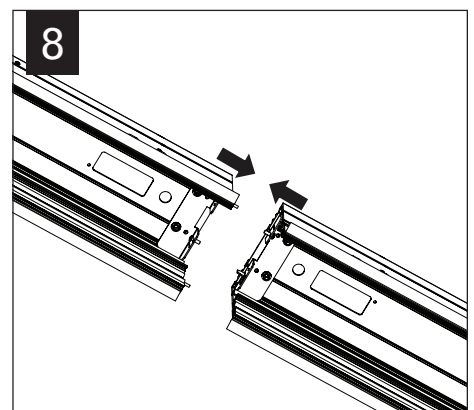

Luminaires must be installed by a qualified electrician (check with local and national codes for proper installation).  
To prevent electrical shock, disconnect electrical supply before installation or servicing.

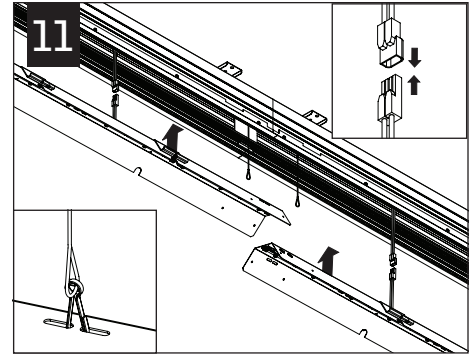
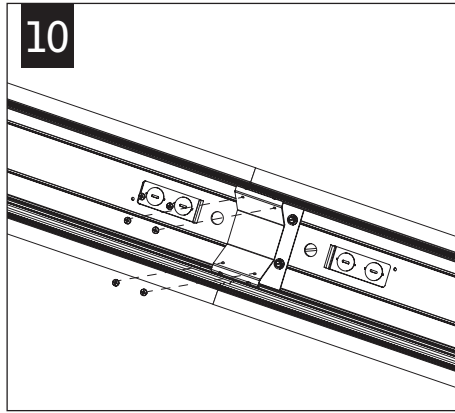
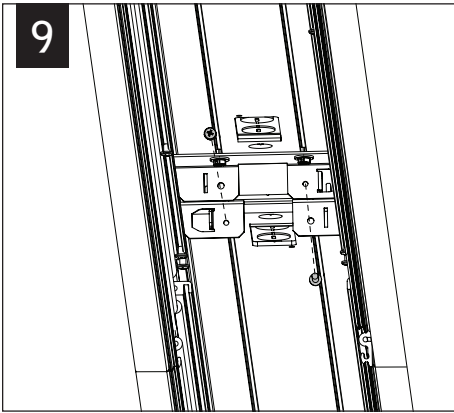

**MAKE ELECTRICAL CONNECTIONS**

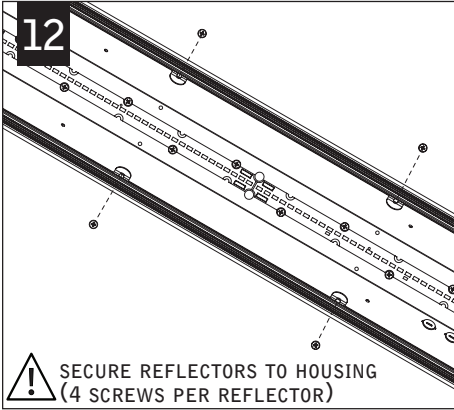

**SECURE REFLECTORS TO HOUSING (4 SCREWS PER REFLECTOR)**



FLUSH LENS

**REFERENCE INSTRUCTIONS ON INCLUDED TOOL FOR LENS INSTALLATION.**

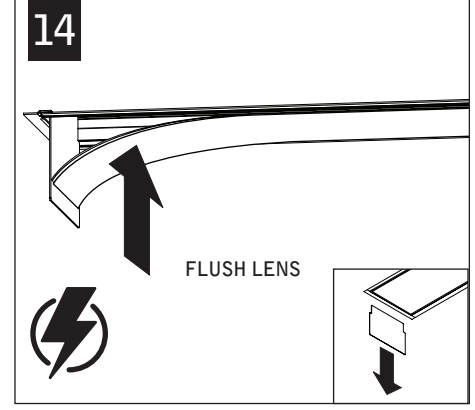

FLUSH LENS

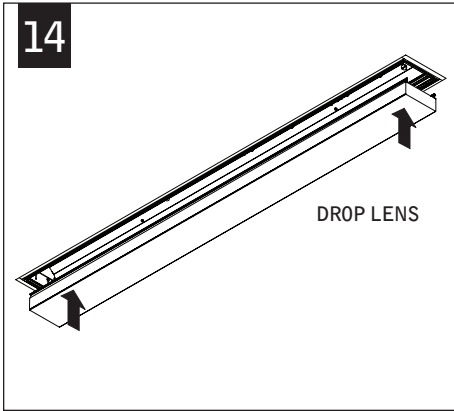

DROP LENS

**EMERGENCY**

**I**

**SEE BATTERY MANUFACTURER INSTRUCTIONS**

EMERGENCY BATTERY  
MAXIMUM MOUNTING HEIGHT: 18.00'

EMERGENCY CIRCUIT  
MAXIMUM MOUNTING HEIGHT: 21.00'

**DRIVER SERVICE**

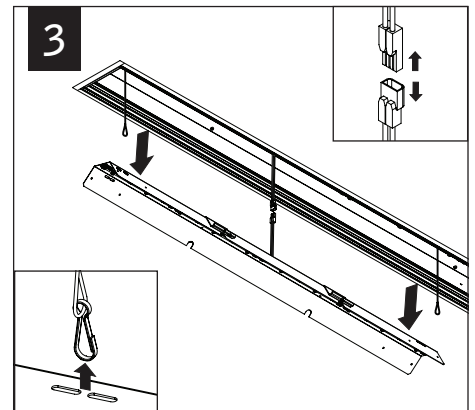
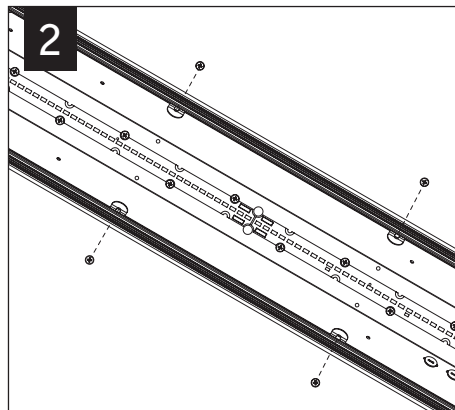
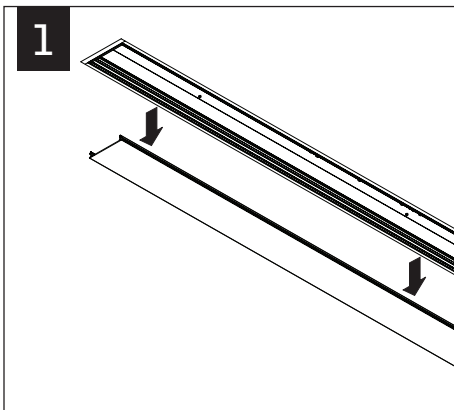

Contractor is responsible for adequately reinforcing walls and/or ceilings to support luminaire weight. Focal Point, LLC accepts no responsibility for inadequately reinforced walls and/or ceilings. The information contained in this drawing is the sole property of Focal Point, LLC. Any reproduction in part or whole without the written permission of Focal Point, LLC is prohibited.