

# Twelve™ LED

SUSPENDED | FTWLS



FOCAL POINT®

## BEFORE YOU BEGIN

- Luminaires must be installed by a qualified electrician (check with local and national codes for proper installation).
- To prevent electrical shock, disconnect electrical supply before installation or servicing.
- Contractor is responsible for adequately reinforcing walls and/or ceilings to support fixture weight.
- Focal Point, LLC accepts no responsibility for inadequately reinforced walls and/or ceilings.
- The information contained in this drawing is the sole property of Focal Point, LLC. Any reproduction in part or whole without the written permission of Focal Point, LLC is prohibited.

## INSTRUCTION KEY

- ATTENTION
- SEE ADDITIONAL INSTRUCTIONS
- POWER OFF
- POWER ON

## COMPONENT KEY

### FOCAL POINT

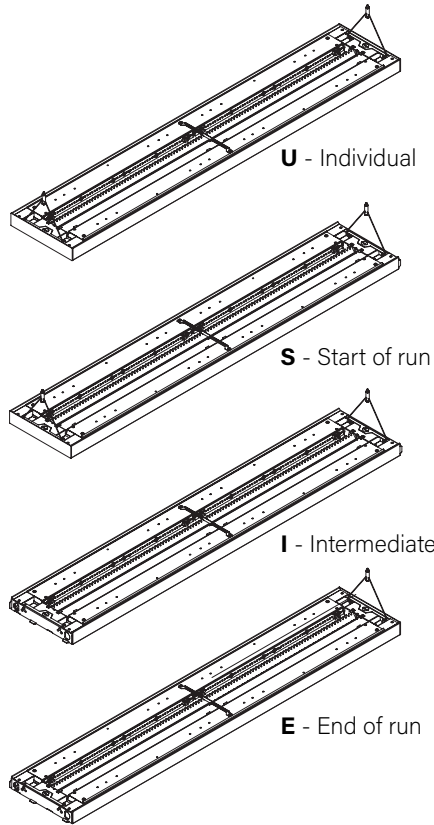

### SHIPPED IN HARDWARE BAG

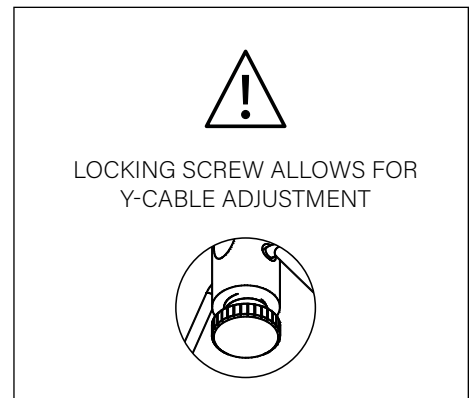

**1**

FOLLOW FOCAL POINT INSTRUCTIONS FOR UNIVERSAL SUSPENSION SYSTEM ASSEMBLY. SEE IS0166

**2**

**3**

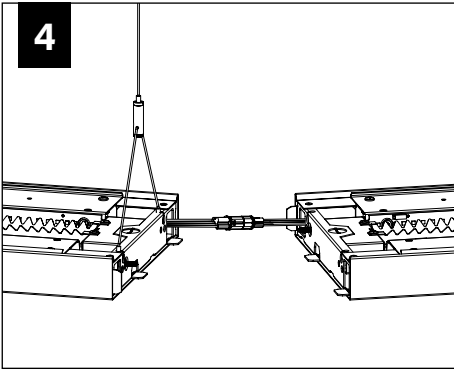

**4**  
MAKE ELECTRICAL CONNECTION

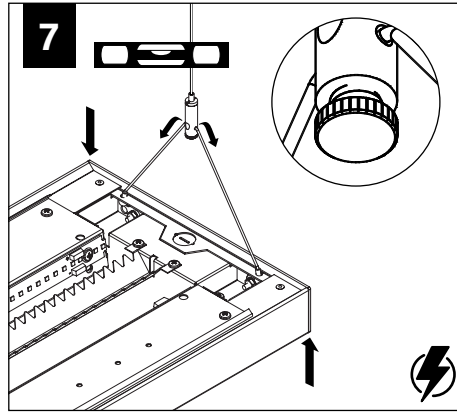
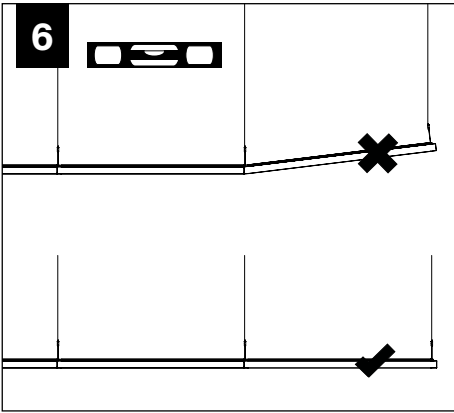
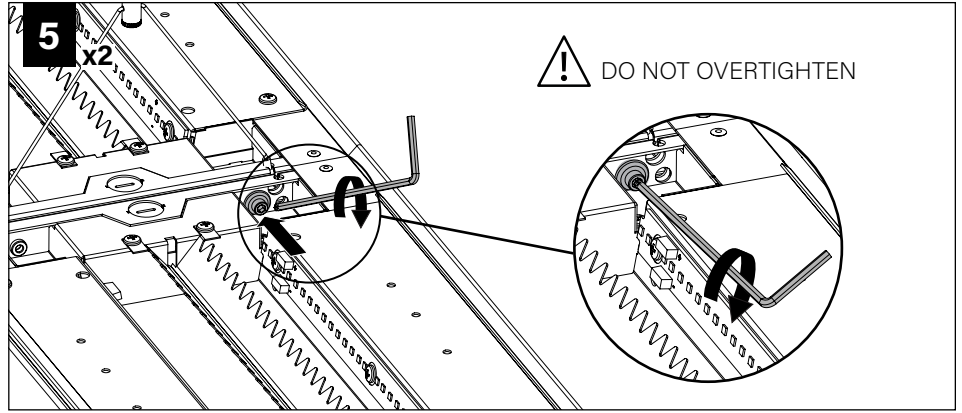

**GRADIENT OPTIC ASSEMBLY**

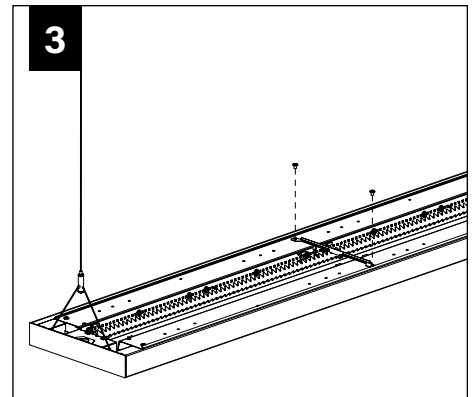
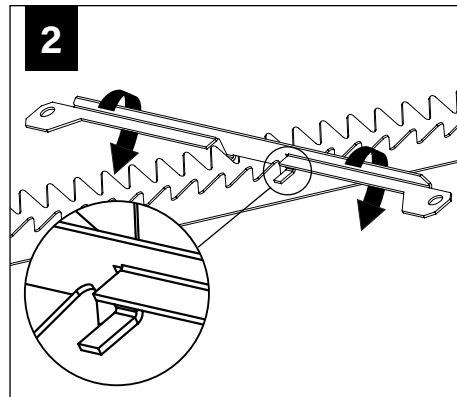
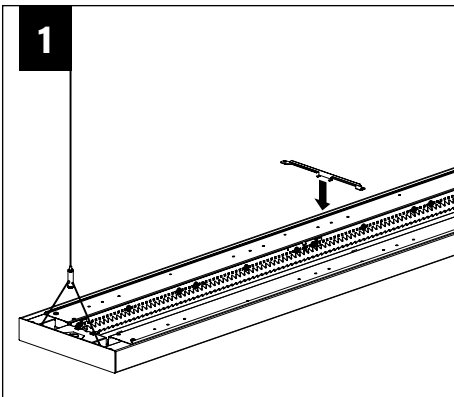

**DRIVER SERVICE**

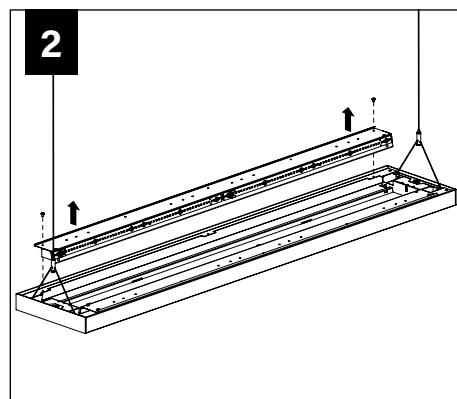
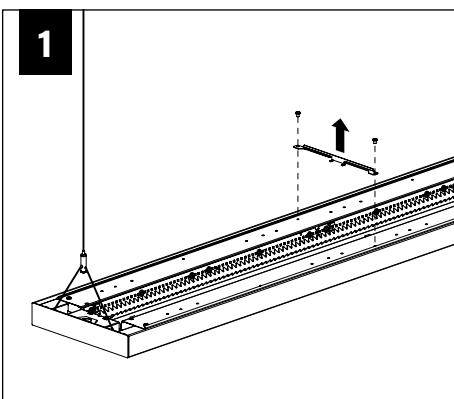

**EMERGENCY**

**I**

SEE BATTERY MANUFACTURER  
INSTRUCTIONS

**EMERGENCY BATTERY MAXIMUM  
MOUNTING HEIGHT: 11'**

**EMERGENCY CIRCUIT MAXIMUM  
MOUNTING HEIGHT: 19**

**ACUITY nLIGHT**

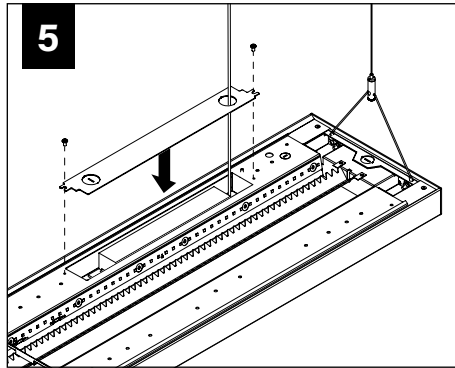
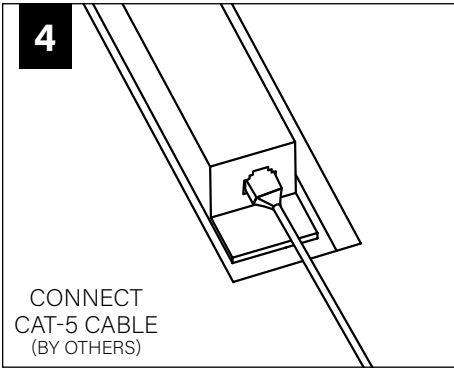
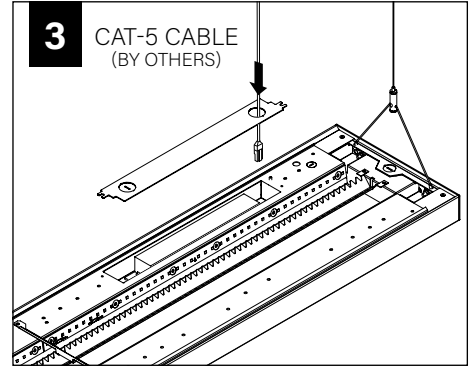
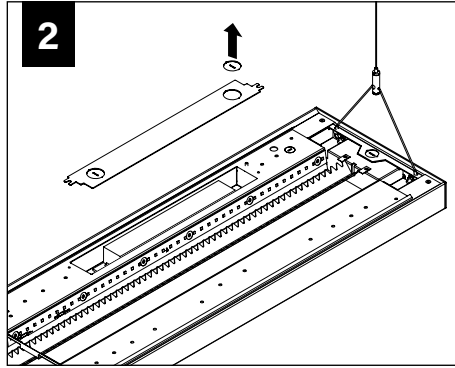
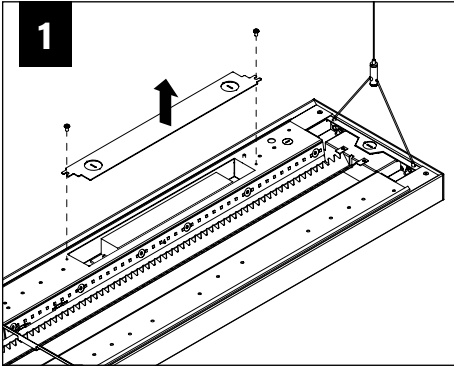

**WATTSTOPPER**

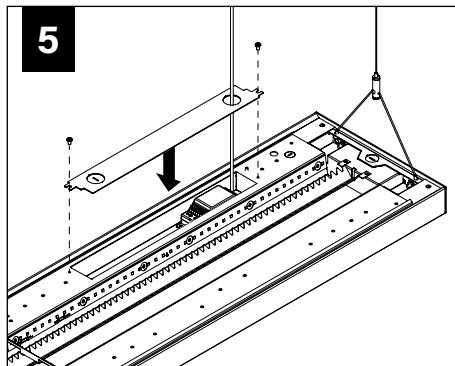
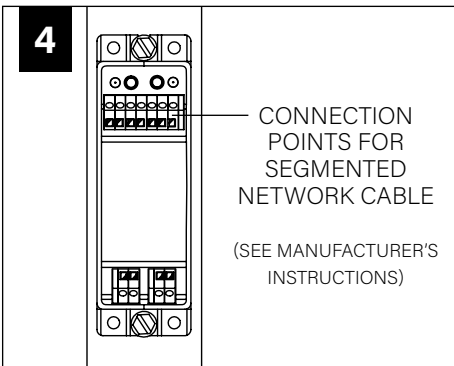
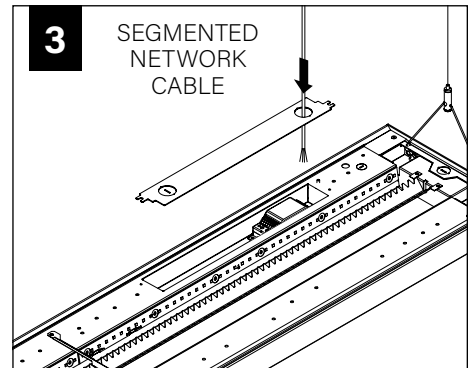
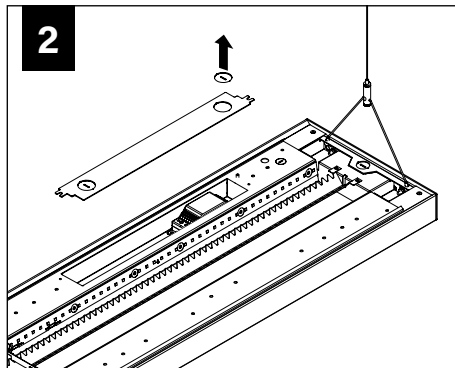
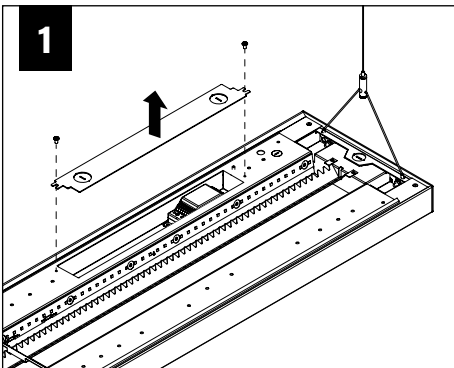

**HUBBELL NX**

