

# verve™ IV led

FV4LS



FOCAL POINT®

## FOCAL POINT

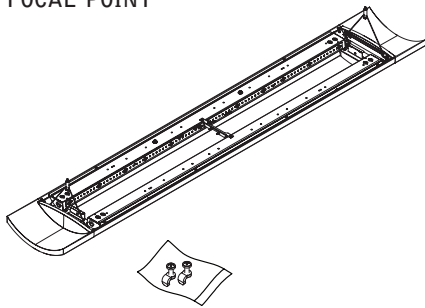

UNIVERSAL SUSPENSION SYSTEM - SHIPS SEPARATELY

OPTIONAL DUST COVER  
8.25" W (+/- .10")

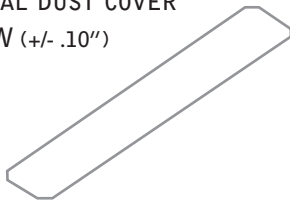

## UNIT DESCRIPTION

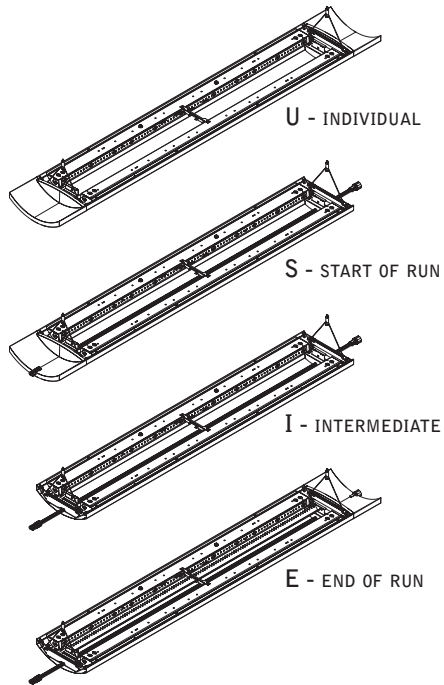

## KEY



POWER OFF



POWER ON



LEVEL



ATTENTION



ADDITIONAL INSTRUCTIONS  
IS0166



KEEP LUMINAIRE IN ORIGINAL  
CARTON UNTIL READY TO INSTALL.  
DO NOT REST ON THE GROUND.



LOCKING SCREW ALLOWS FOR  
Y-CABLE ADJUSTMENT

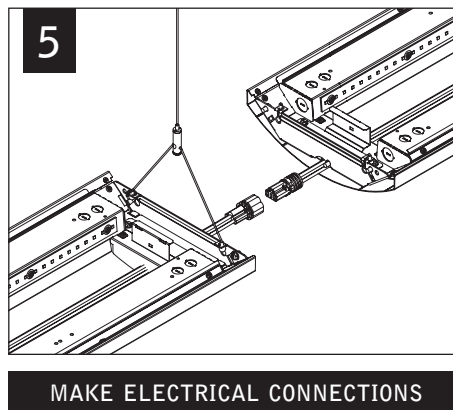
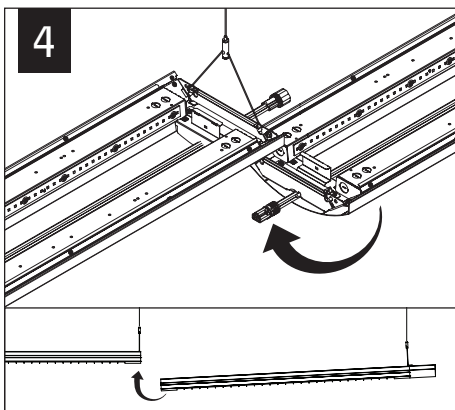
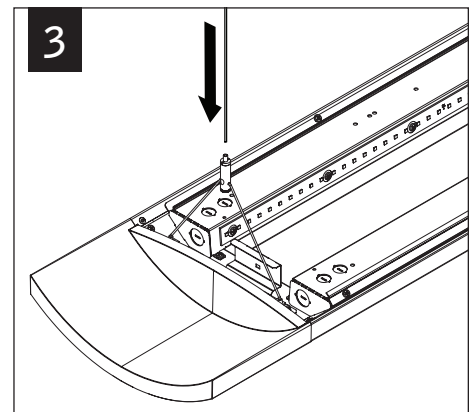
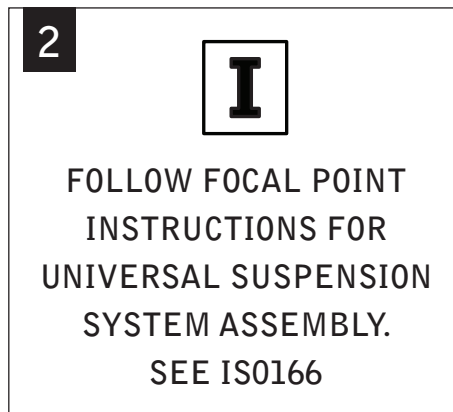

Luminaires must be installed by a qualified electrician (check with local and national codes for proper installation).  
To prevent electrical shock, disconnect electrical supply before installation or servicing.

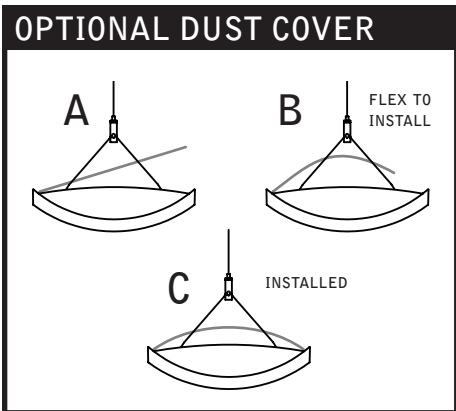
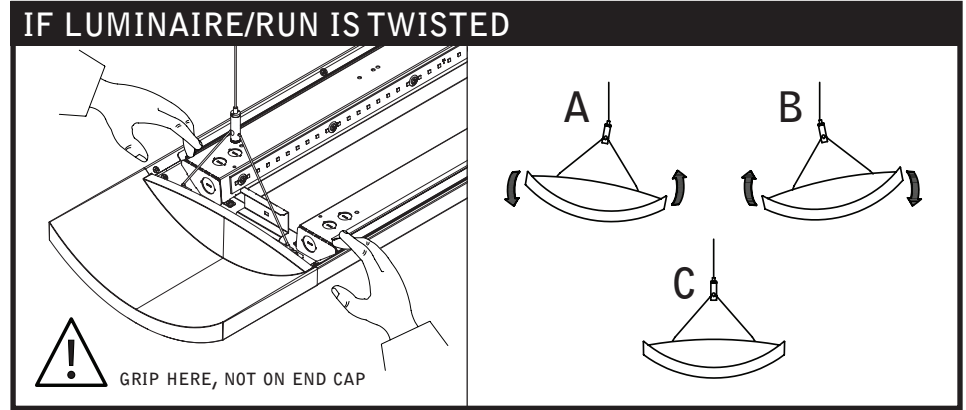
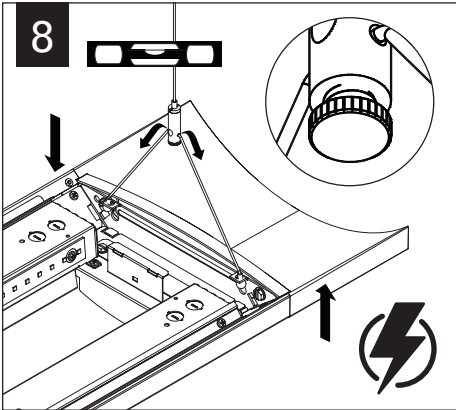
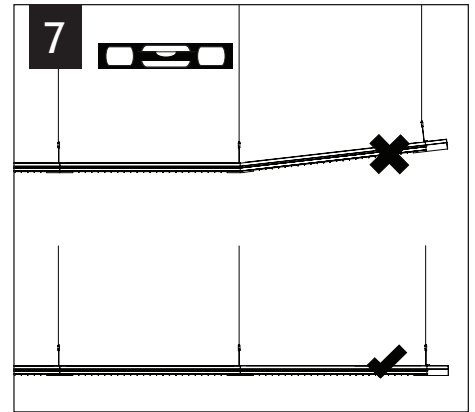
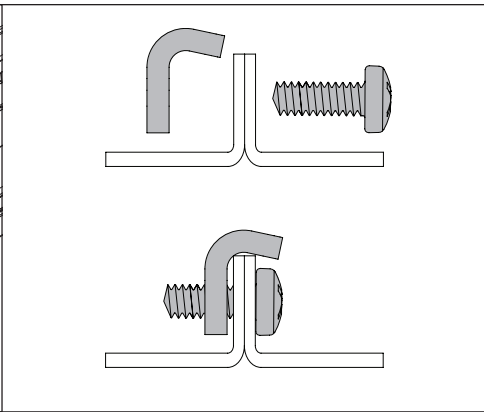
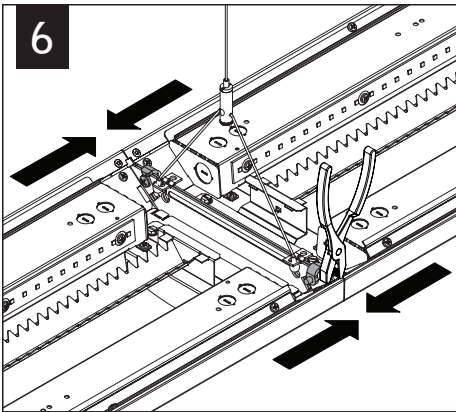

**DRIVER SERVICE**

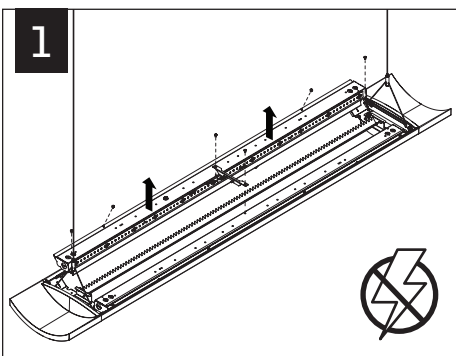

Luminaires must be installed by a qualified electrician (check with local and national codes for proper installation).  
 To prevent electrical shock, disconnect electrical supply before installation or servicing.

# CONNECTED SOLUTIONS

## ACUITY nLIGHT

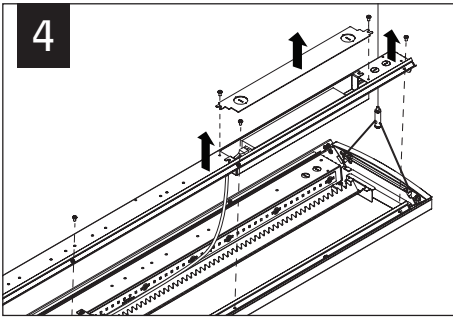
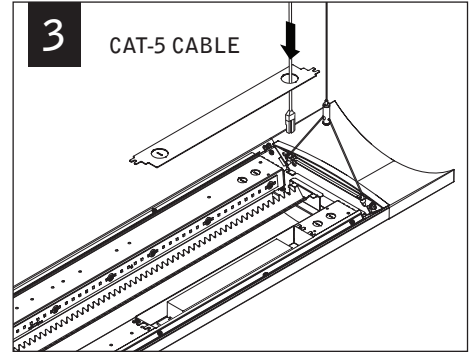
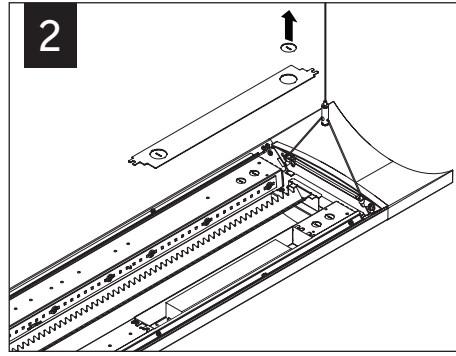
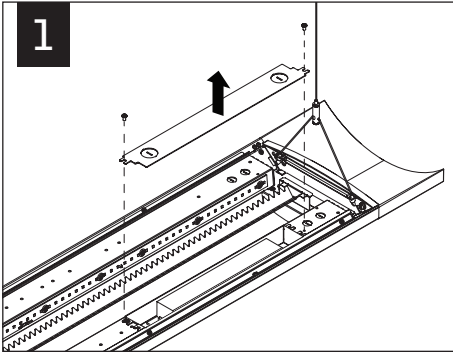

JOINED RUNS

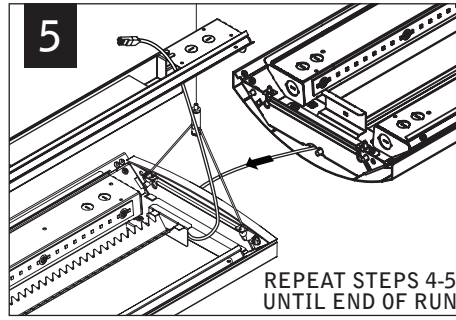

JOINED RUNS

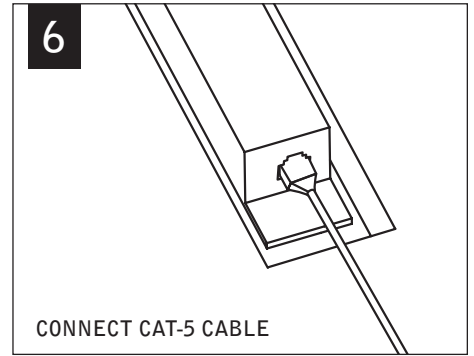

CONNECT CAT-5 CABLE

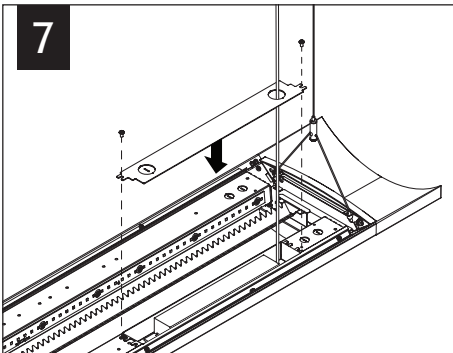

## WATTSTOPPER

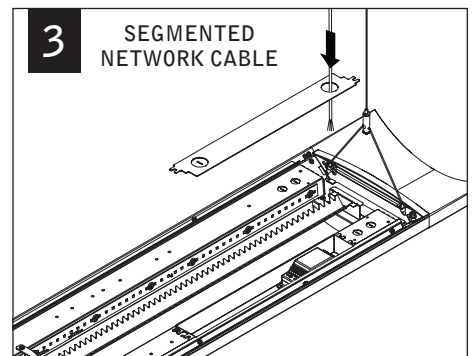
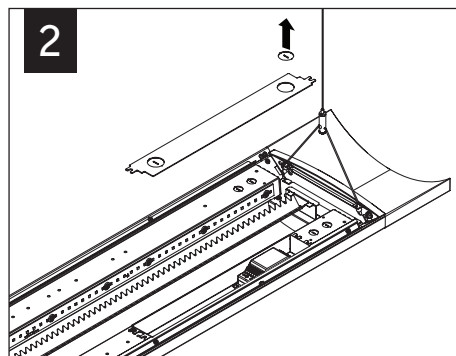
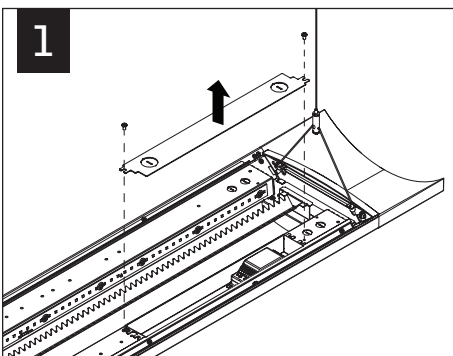

Luminaires must be installed by a qualified electrician (check with local and national codes for proper installation).  
To prevent electrical shock, disconnect electrical supply before installation or servicing.

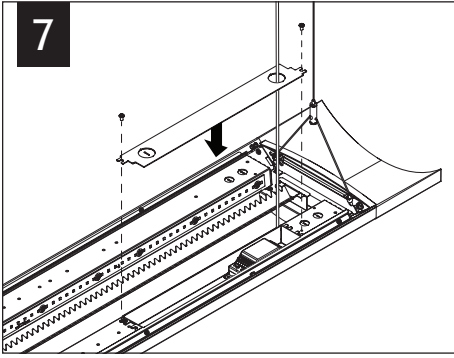
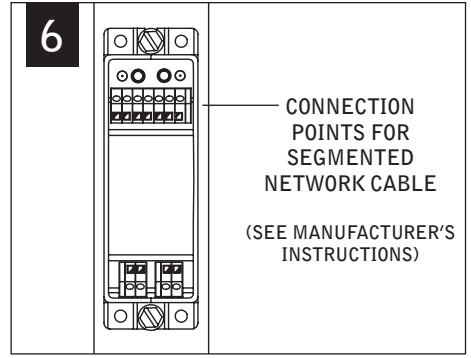
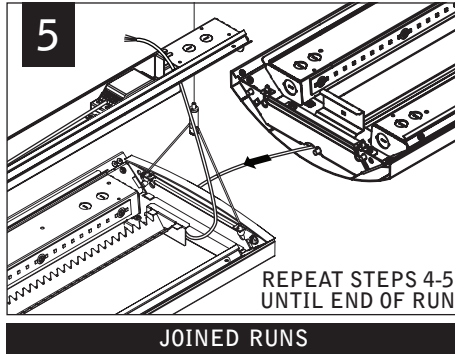
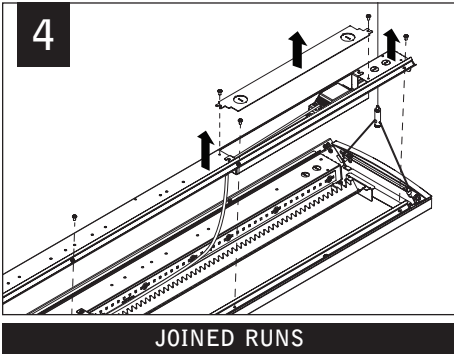

Contractor is responsible for adequately reinforcing walls and/or ceilings to support luminaire weight. Focal Point, LLC accepts no responsibility for inadequately reinforced walls and/or ceilings. The information contained in this drawing is the sole property of Focal Point, LLC. Any reproduction in part or whole without the written permission of Focal Point, LLC is prohibited.