

FOCAL POINT

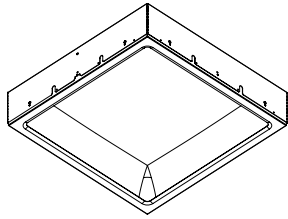

GRID HARDWARE



FLANGELESS HARDWARE

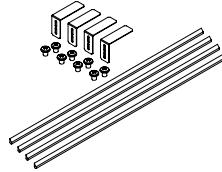

KEY



POWER OFF

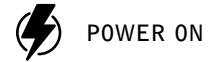

POWER ON



ATTENTION

GRID

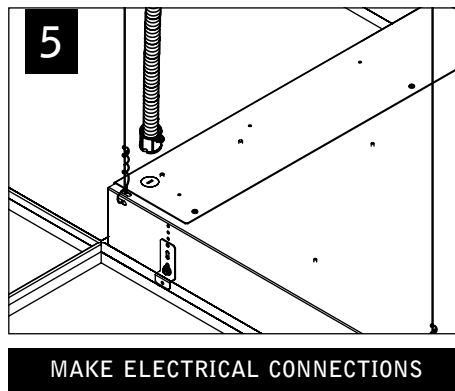
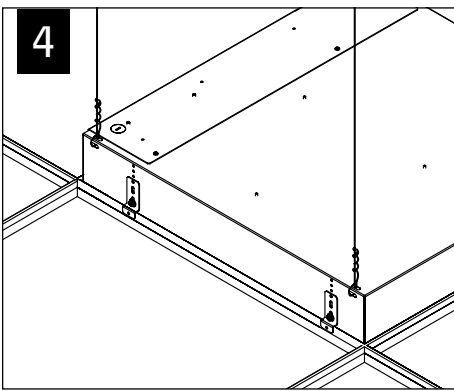
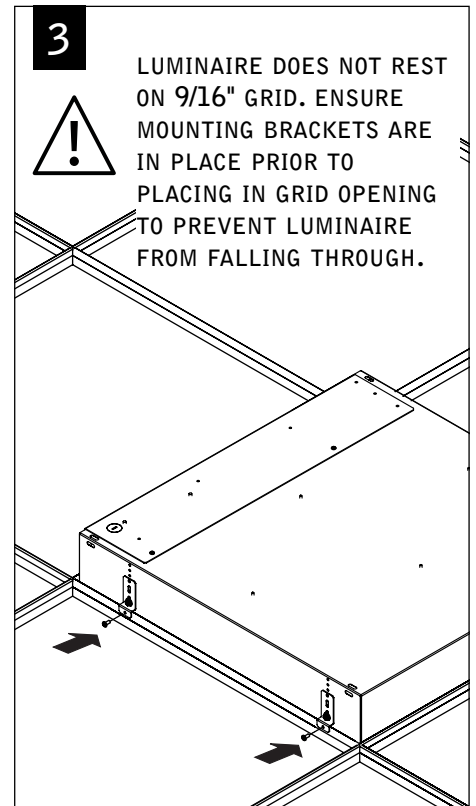
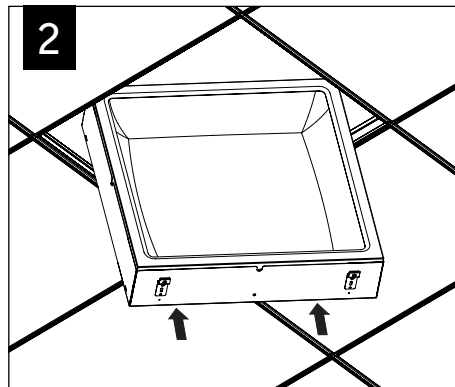
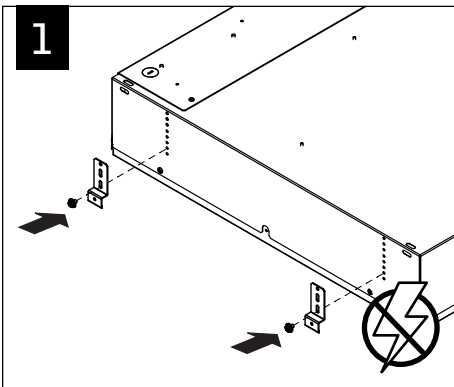

DRYWALL FRAME KIT

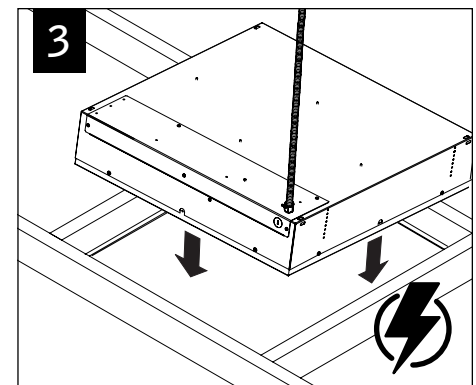
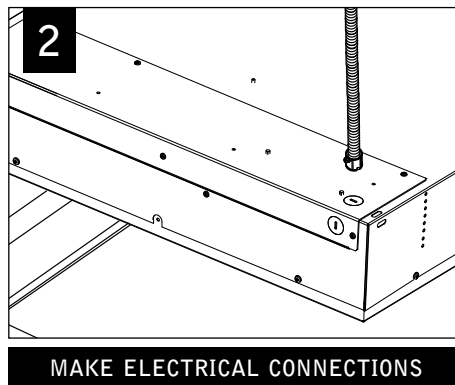
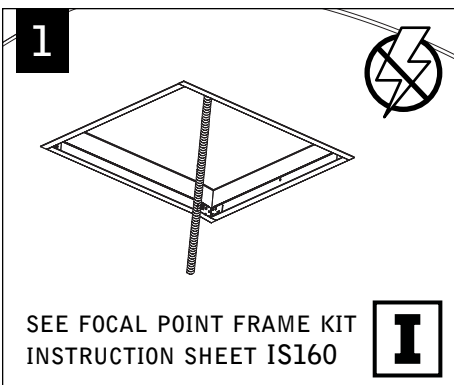

Luminaires must be installed by a qualified electrician (check with local and national codes for proper installation).
To prevent electrical shock, disconnect electrical supply before installation or servicing.

FLANGELESS HARD SURFACE

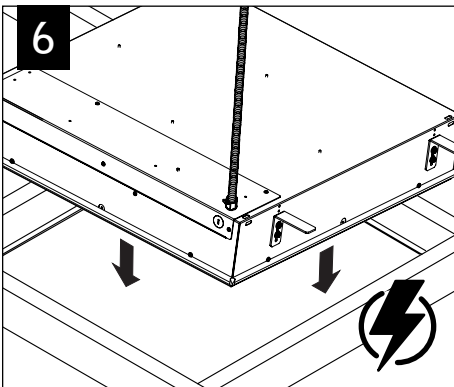
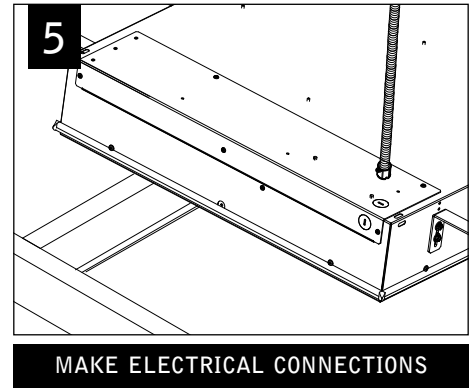
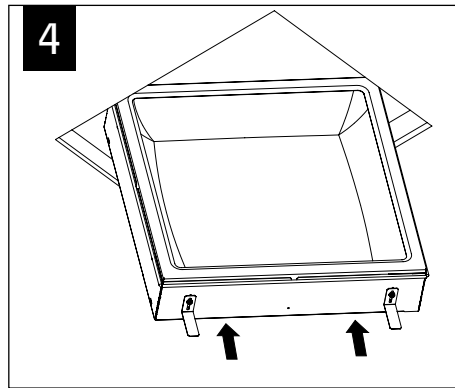
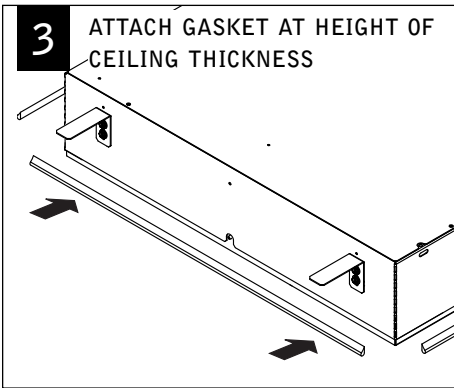
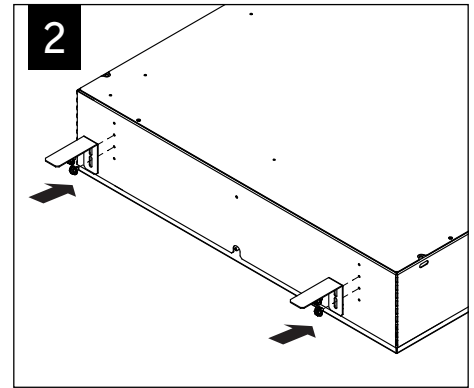
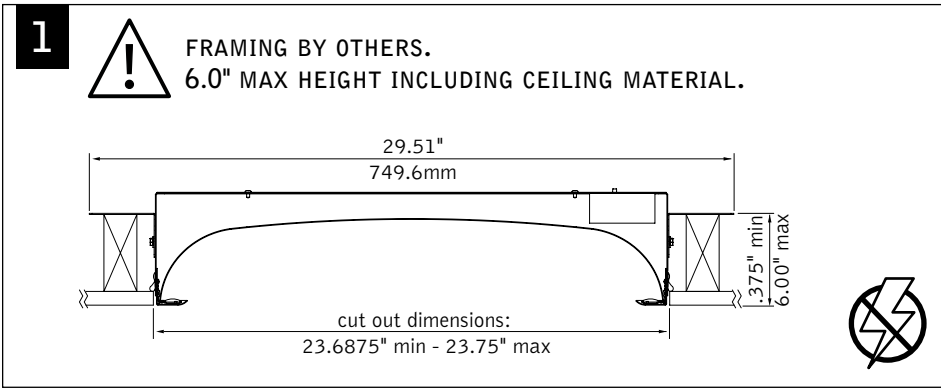

DRIVER SERVICE



DRIVER IS ONLY SERVICEABLE FROM ABOVE

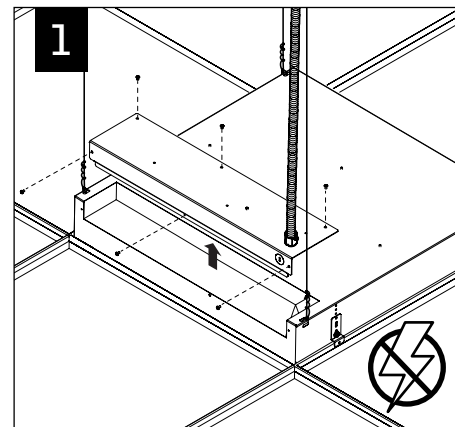

EMERGENCY



SEE BATTERY MANUFACTURER INSTRUCTIONS

EMERGENCY MAXIMUM MOUNTING HEIGHT: 14.00'

Contractor is responsible for adequately reinforcing walls and/or ceilings to support luminaire weight. Focal Point, LLC accepts no responsibility for inadequately reinforced walls and/or ceilings. The information contained in this drawing is the sole property of Focal Point, LLC. Any reproduction in part or whole without the written permission of Focal Point, LLC is prohibited.