

Seem® 1 Vanity

FSM1BV



FOCAL POINT®

BEFORE YOU BEGIN

- Luminaires must be installed by a qualified electrician (check with local and national codes for proper installation).
- To prevent electrical shock, disconnect electrical supply before installation or servicing.
- Contractor is responsible for adequately reinforcing walls and/or ceilings to support fixture weight.
- Focal Point, LLC accepts no responsibility for inadequately reinforced walls and/or ceilings.
- The information contained in this drawing is the sole property of Focal Point, LLC. Any reproduction in part or whole without the written permission of Focal Point, LLC is prohibited.

INSTRUCTION KEY

- ATTENTION
- SEE ADDITIONAL INSTRUCTIONS
- POWER OFF
- POWER ON

COMPONENT KEY

FOCAL POINT

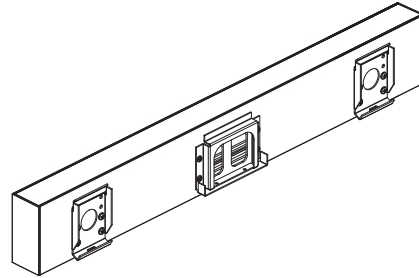

Mounting Rail

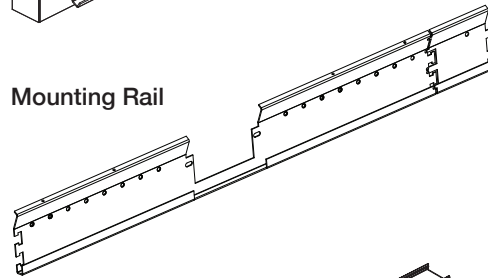

Flush Lens

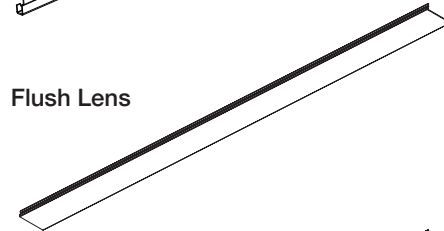

0.5" Pop-Down Lens

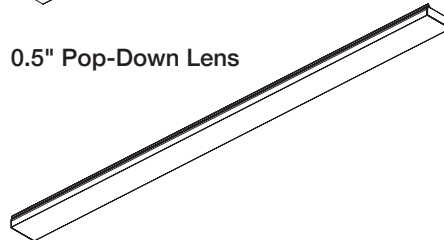

SHIPPED INSTALLED



Reflector Screw (72026)
(6-32 x 1/4 SELF TAPPING SCREW)

SHIPPED IN HARDWARE BAG



Mounting Screw (72007)
(2 per luminaire)

Asymmetric

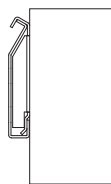

Flush Lens

Dust Cover

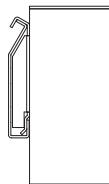

Flush Lens

Asymmetric

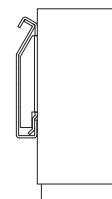

0.5" Pop-Down

Dust Cover

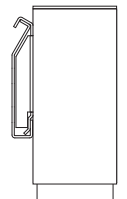

0.5" Pop-Down

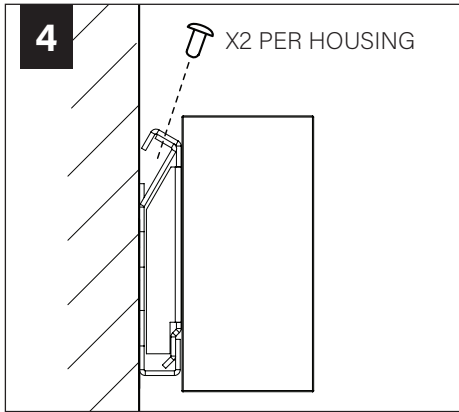
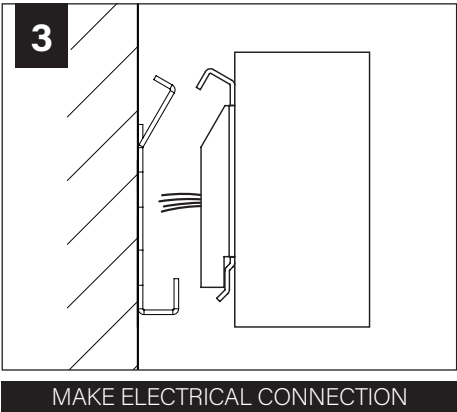
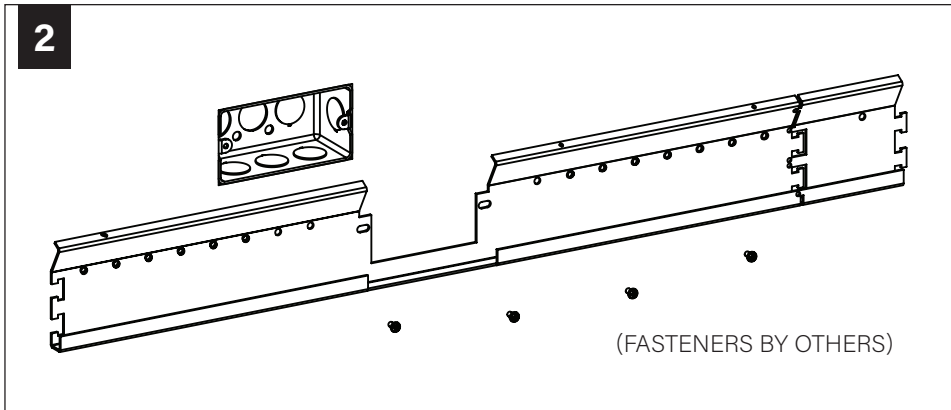
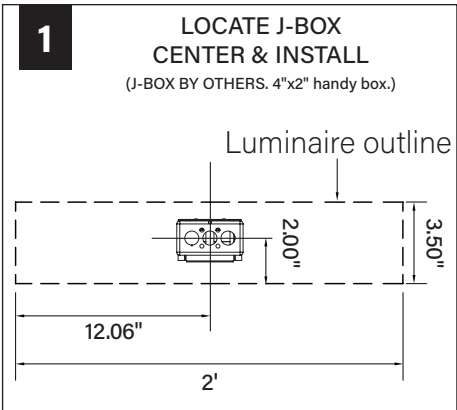

DRIVER SERVICE

