

Seem® 2 Vanity

FSM2BV



BEFORE YOU BEGIN

- Luminaires must be installed by a qualified electrician (check with local and national codes for proper installation).
- To prevent electrical shock, disconnect electrical supply before installation or servicing.
- Contractor is responsible for adequately reinforcing walls and/or ceilings to support fixture weight.
- Focal Point, LLC accepts no responsibility for inadequately reinforced walls and/or ceilings.
- The information contained in this drawing is the sole property of Focal Point, LLC. Any reproduction in part or whole without the written permission of Focal Point, LLC is prohibited.

INSTRUCTION KEY

- ATTENTION
- SEE ADDITIONAL INSTRUCTIONS
- POWER OFF
- POWER ON

COMPONENT KEY

FOCAL POINT

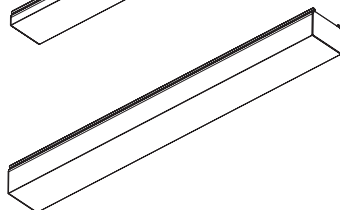
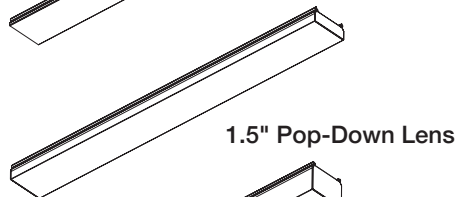
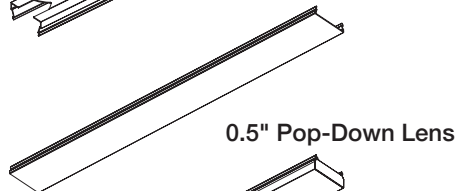
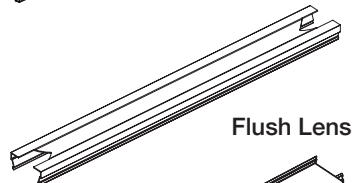
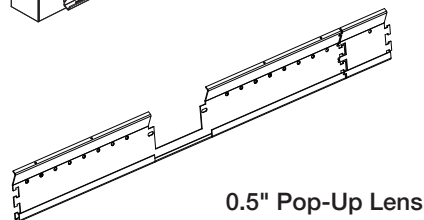
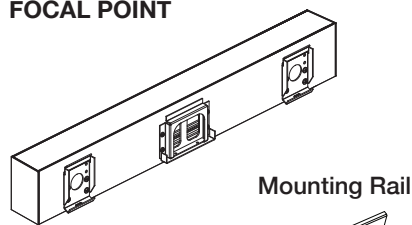

SHIPPED INSTALLED



SHIPPED IN HARDWARE BAG

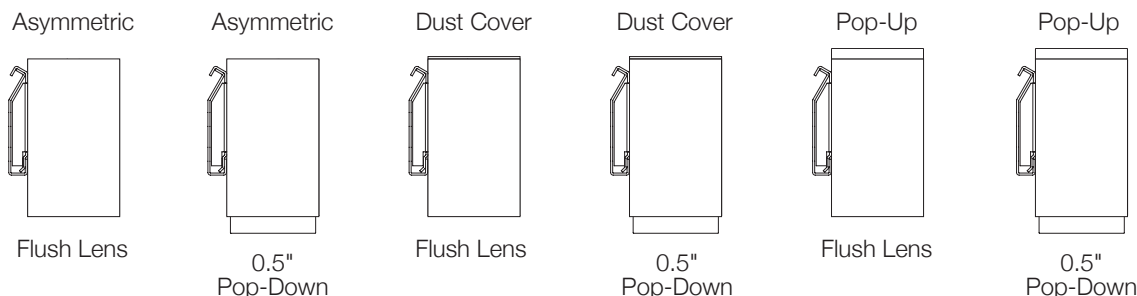

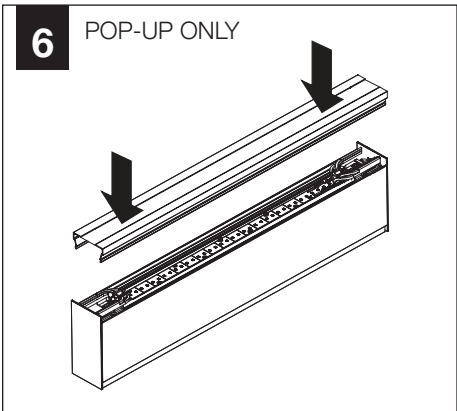
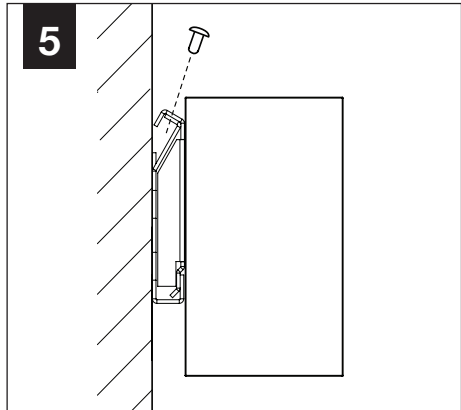
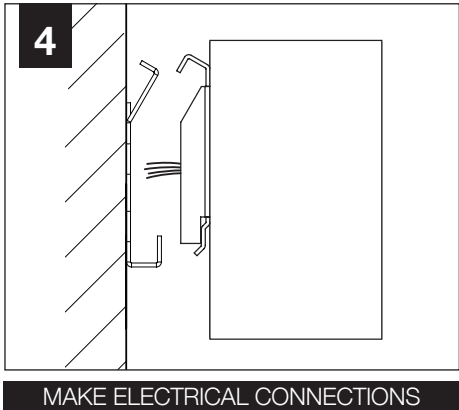
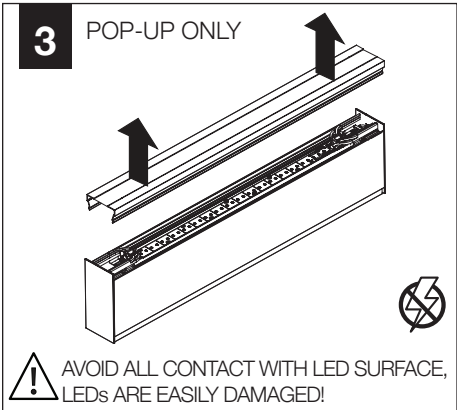
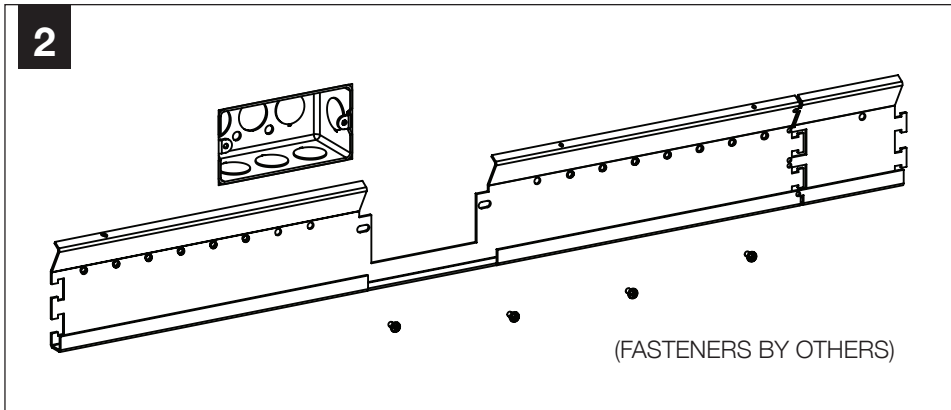
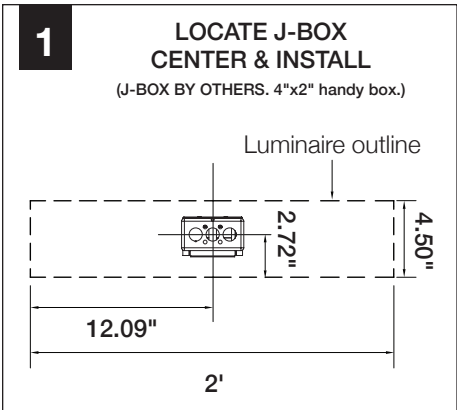

DRIVER SERVICE

